

Anchorseal with G.I.wire 180mm

Wire seal



Specifications

- Seal made of polycarbonate and ABS
- To be used with different sealing wires or strings. Any pliers for the correct closure is required.
- Working temperature: up to 80°C
- Equipped with 180mm galvanised sealing wire or stainless steel wire
- Marking: laser
- Progressive numbering up to 7 digits
- Logo and barcode available options
- Customisation up to 10 characters on one line
- Body of the seal available both in transparent or plain colour
- Available colours for the insert: blue, white, yellow, red and green
- Further colours may be manufactured upon request

Specifications and design are subject to change without any notice or obligation from the manufacturer

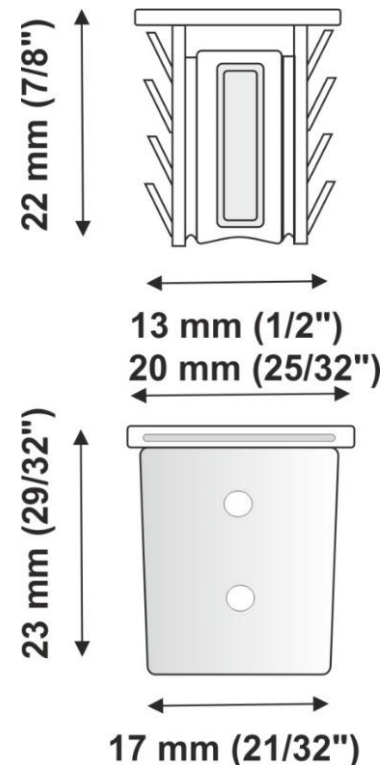

Packaging

- Box with 5000 seals
- Box size: 56x36x56cm
- Box weight: 17.5 kg

CUSTOMS CODE: 39269097

info@leghorngroup.in

Protection - Control - Identification - Tracking - RFID solutions - www.leghorngroup.in

