

Twistseal

Wire seal



Specifications

- Seal made of polycarbonate and ABS
- To be used with different sealing wires or strings. Any pliers for the correct closure is required.
- Working temperature: -30°C +60°C
- Marking: laser
- Progressive numbering up to 15 digits
- Logo and barcode available options
- Customisation up to 20 characters on one line
- Body of the seal available both in transparent or white colour
- Available colours for the insert: orange, blue, white, yellow, red and green



- Further colours may be manufactured upon request

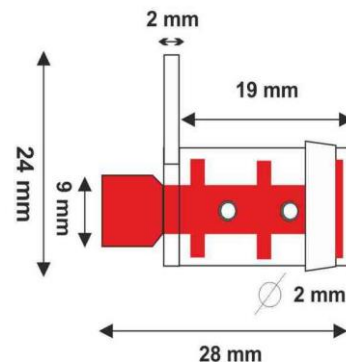
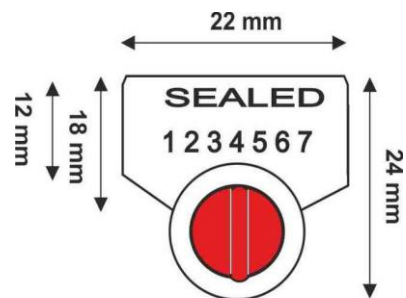

Specifications and design are subject to change without any notice or obligation from the manufacturer

Packaging

- Box with 1000 seals in bags of 100 pcs
- Box size: 40x24x17cm
- Box weight: 3,1 kg
- Pallet: 80x120x185cm, 330 kg, 100000 pcs

CUSTOMS CODE: 39269097

info@leghorngroup.in

Protection - Control - Identification - Tracking - RFID solutions - www.leghorngroup.in

